

1281

Filtro depurazione acqua con flange PN6/PN16
Horizontal intake water strainer with PN6/PN16 flanges

Filtro omologato RINA MAC
RINA MAC certificate



Tabella flange a pag. 195
Flange table on page 195

* Con flangia PN16
With flange PN16

	1281	14500	21000	26000	39000	50000	80000	138500
Weight (gr)*	10900	14500	21000	26000	39000	50000	80000	138500
	3281	4950	7150	8840	13260	17000	27200	47100
Weight (gr)*	3750	4950	7150	8840	13260	17000	27200	47100
d	8.5	8.5	8.5	8.5	8.5	8.5	10.5	10.5
A	108	122	142	166	188	214	260	320
B	108	122	132	150	170	210	240	280
H	225	273	302	350	430	468	575	685
H1	147	184.5	205	243	306	325.5	400	485
L1	102	117	130	150	170	190	215	255
L	225	260	290	338	380	425	500	600
DN	50	65	80	100	125	150	200	250

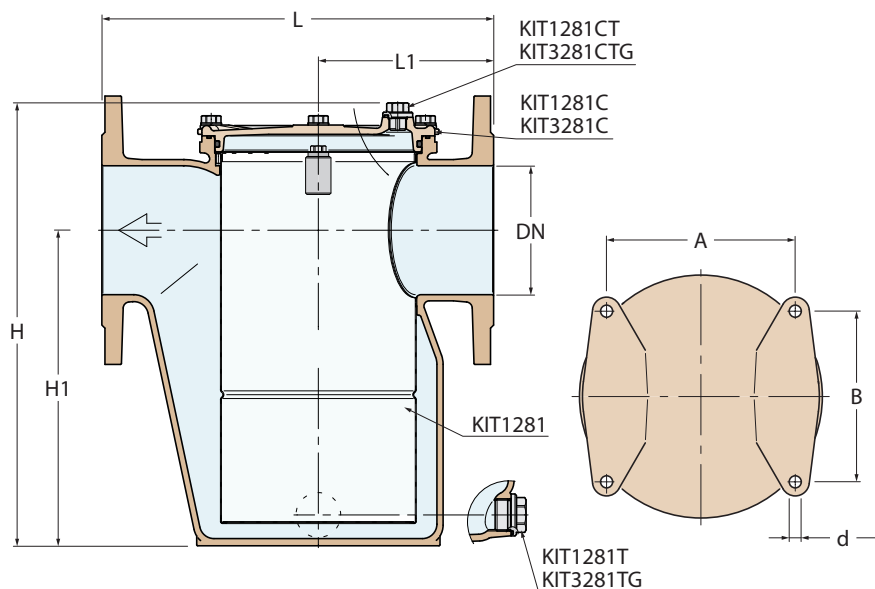

Bronzo
Bronze

3281



Alluminio anodizzato nero
Solo su richiesta speciale
Black anodized aluminium
Upon special request only

Diagramma portate - perdite di carico
Flow rate - loss of pressure diagram

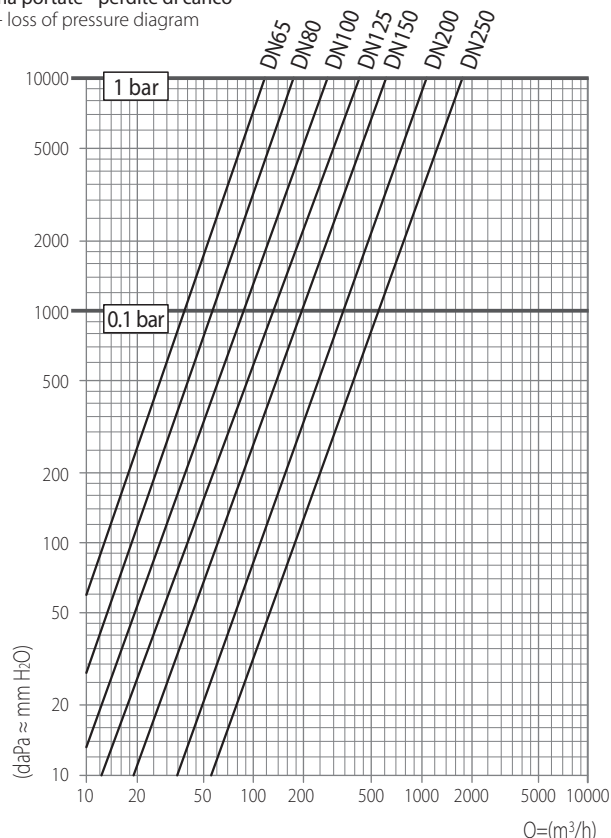

Corpo in bronzo / Alluminio anodizzato nero
Bronze / Black anodized aluminium casing

Elemento filtrante in acciaio inox AISI 316L
AISI 316L stainless steel inside filter

Coperchio in bronzo / Alluminio anodizzato nero
Bronze / Black anodized aluminium cover

Guarnizioni in neoprene
Neoprene o-ring

DN	0.1 bar	1 bar
65	37000	117000
80	56100	177200
100	88000	277000
125	136800	432700
150	197000	623000
200	350000	1108000
250	564500	1786000

Portate di acqua attraverso il filtro pulito - lt/h
Flow-rate capacity through the clean filter - lt/h